

**ĆELIJSKI DOZATOR
ZAPORNIK**

**ROTARY DOZER
AIR-LOCK**

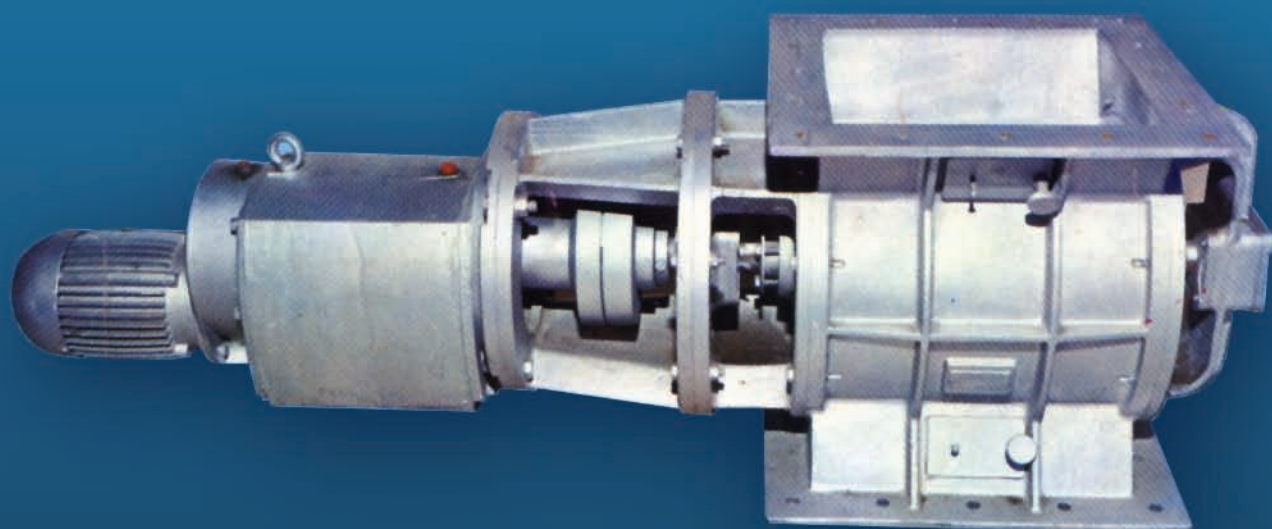

Demos d.o.o.

**Tvornica za projektiranje, proizvodnju, montažu i servisiranje,
opreme za zaštitu okoliša**

PRIMJENA

Ćelijski dozator-zapornik upotrebljava se u cementnoj, kemijskoj i procesnoj industriji kao element pneumatskog transporta, otprašivanja ili doziranja. Ugrađuje se na uređajima da sprječi izjednačenje pritiska, a omogućiti nesmetani protok materijala, ili služi kao dozator sipkih materijala.

IZVEDBA

Ćelijski dozator-zapornik izrađen je u ljevanoj izvedbi. Dozator-zapornik sastavljen je od kućišta, rotora sa ćelijama, ćelnim poklopcima sa kugličnim ležajevima, osovine i prigona koji se sastoji od reduktora i spojke ili lančanika i lanca. Ćelijski dozator izrađuje se u tri veličine Do 200, Do 300 i Do 400 te dvije varijante. Prva varijanta rađena je za teške uvjete rada i temperaturu do 350°C.

Zbog tih uvjeta ležajevi su smješteni izvan ćelnih poklopaca a pojačana je i snaga motora. U drugoj varijanti za normalne uvjete rada ležajevi su ugrađeni u ćelne poklopce. Na mjernoj skici prikazana je naša tipiska izvedba ćelijskih dozatora pogonjena motorreduktorom izvedbe B5.

Na zahtjev, ćelijske dozatore-zapornike isporučujemo bez pogona ili u pogonskoj izvedbi sa motorreduktorom izvedbe B3 smješten na zajedničkom okviru spojen preko elastične spojke ili para lančanika i lanca.

Za fina i promjenjiva doziranja na isti način može se ugraditi frekventni regulator broja okretaja.

IZBOR DOZATORA

Kod odabiranja dozatora-zapornika potrebno je uzeti u obzir slijedeće podatke:

- Q_t - količina materijala u t/h ili
- Q_m - količina materijala u m³/h
- γ - nasipna težina materijala u t/m³
- Δ_p - statički tlak mm SV
- f_n - faktor nasipa materijala

Osim ovih tehničkih podataka potrebno je voditi računa o: finoći, sipkosti, korozivnosti i higroskopnosti materijala. Zbog okretanja nije moguće ispuniti stvarni volumen rotora normalnim nasipom iz bunkera, te je ispunjavanje uvijek manje.

Faktor nasipa (f_n) ovisan je o broju okretaja rotora sipkosti i nasipnoj težini materijala. Prema tome kapacitet dozatora je:

$$Q_{Do} = \frac{Q_t}{f_n} t/h$$

gdje nam je:

$$Q_t = Q_m \times \gamma t/h$$

Kod pogona kada rotirajući ćelijski dozator služi kao zapornik tada njegov kapacitet odredimo prema ukupnoj količini odvojene prašine plus 30% povećanja kapaciteta.

To je potrebno da dobijemo jednoliko pražnjenje bunkera jer bunker nisu deponije prašine. Za preciznije doziranje materijala najprikladniji je frekventni regulator jer tada možemo postupnim mjenjanjem broja okretaja dobiti željeni kapaciteta s mogućnošću odstupanja $\pm 0,5\%$.

Kako vidimo, za točan proračun treba uzeti u obzir eksperimentalne ili iskustvene podatke s obzirom na mnoštvo nepoznatih utjecaja. Na diagramu kapaciteta (sl. 7) prikazani su kapaciteti dozatora sa već uračunatim faktorom nasipa $f_n = 0,8$. Područje naše tipiske izvedbe je posebno naznačeno.

U tablici tehničkih podataka tipiske izvedbe rotirajućih ćelijskih dozatora – zapornika vidljivi su svi potrebni podaci za navedene dozatore.

APPLICATION

Rotary dozer air-lock is used in the cement, chemical and process industry as an element in pneumatic transport, de-dusting or dozing. This element is built onto units in order to prevent equalization of pressure and allows the free passing of material, or acts as a dozer for grain material.

MODEL

Rotary dozer air-lock model is built. It consists of a housing, rotor with cells, covers with roller bearings, shaft and drive, which consists of gearbox, chain, and coupling of chain bridge. The rotary dozer is manufactured in three sizes: Do 200, Do 300, Do 400, and in two models.

The first model is anticipated for difficult working conditions and temperatures up to 350°C. Due to these conditions, bearings are placed outside of covers and motor power is reinforced.

The second model is anticipated for the normal working conditions. This model has roller bearings built in coverings. On the scale drawing our standard type of rotary dozers is shown, driven by motor gearbox type B5. By request we also deliver dozers without drive or with motor gearbox drive type B3 installed on the common frame connected by spring connection or by pair of chain bridges or chains.

In order to obtain very fine and changeable dozing, gearboxes can be built in for certain dozing selections (refer to the workshop drawings).

DOZER SELECTION

When selecting a Dozer – Air-Lock, the following data should be considered:

- Q_t - quantity of material in t/h or
- Q_m - quantity of material in m³/h
- γ - bulk weight of material in t/m³
- Δ_p - static pressure mm WC
- f_n - material bulk factor

Besides this, the following characteristics of the material should be considered: the hygroscopicity, fineness, purity, and corrosiveness. Due to the rotation it is impossible to fill the actual volume of the rotor by normal bunker filling so that it is always under-filled.

Bulk factor (f_n) depends on the number of revolutions of the rotor, material purity, and its bulk weight. Consequently, the dozer capacity is:

$$Q_{Do} = \frac{Q_t}{f_n} t/h$$

where

$$Q_t = Q_m \times \gamma t/h$$

When the rotary dozer is used as an air-lock then its capacity is determined on the basis of the total quantity of separated dust plus 30% increased capacity. This is necessary in order to obtain a uniform discharge of the bunker, as they do not serve for dust storage.

The variator drive is most suitable for obtaining more precise dosage of material since the desired capacity can be obtained by gradual change of number of revolutions with $\pm 0,5\%$ discrepancy.

Since there is a lot of unknown influences, experimental or experience proved data should be considered in order to obtain exact calculation.

The capacity diagram (Fig. 7) shows the dozer capacity with calculated bulk factor $f_n = 0,8$. The area of our standard type is specially marked.

All necessary data about the standard type of the Dozer – Air-lock are given in the Technical data table that follows.

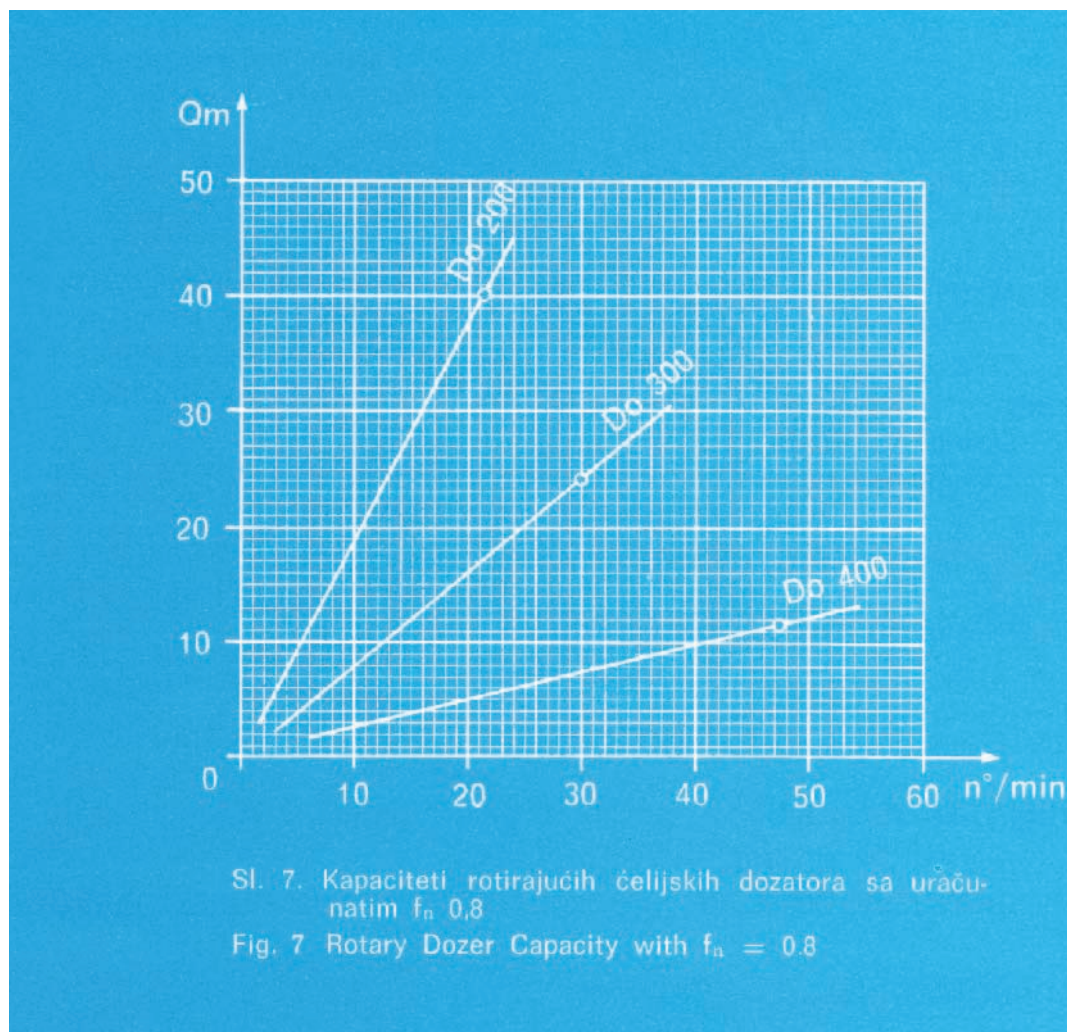

Tablica tehničkih podataka tipske izvedbe rotirajućih čelijskih dozatora – zapornika.
 Standard type technical data

Tip	Volumen rotora dm^3	n o/min	Kapacitet Q_m / $f_n=0,8$ /	Instalirana snaga KW	Tip reduktora	Informativna težina kg Approx. weight	
Type	Rotor volume	opm	Capacity	Power	Gear type	sa reduktorom with gear	bez reduktora without gear
1	2	3	4	5	6	7	8
Do-200	5,0	47	11,3	0,75	3 G3 F80	202	152
Do-300	16,6	32	22,4	1,5	3 G4 F100	368	258
Do-400	42,0	21	40,0	2,2	4 G5 F100	545	370
Do-200-1	5,0	45	11,3	0,55	3 G2 F80	158	111
Do-300-1	16,6	29	22,4	1,1	3 G3 F100	280	230
Do-400-1	42,0	21	40,0	1,5	4 G4 F90	413	328

IZVEDBENA SKICA
WORKSHOP SKETCH

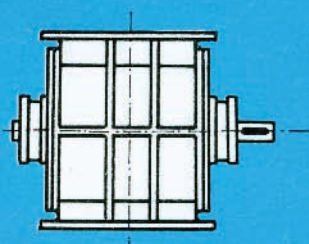

Sl. 1. Dozator.
Fig. 1 Dozer

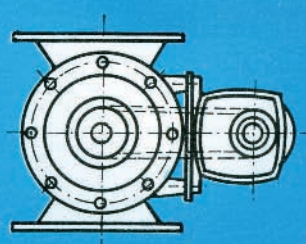

Sl. 4. Dozator sa bočnim pogonom
Fig. 4 Dozer with side drive

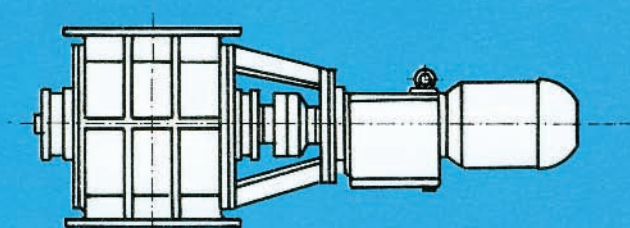

Sl. 2. Dozator sa čelnim pogonom B-5
Fig. 2 Dozer with front drive B-5

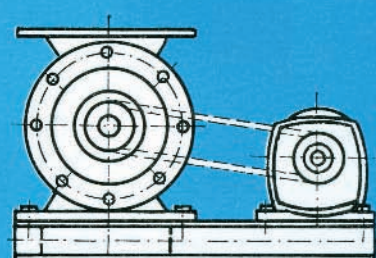

Sl. 5. Dozator sa bočnim pogonom i okvirom
Fig. 5 Dozer with side drive and frame

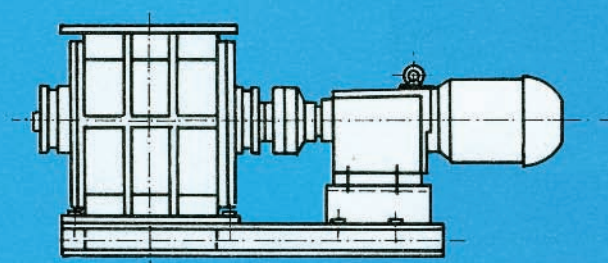

Sl. 3. Dozator sa čelnim pogonom B-3 i okvirom
Fig. 3 Dozer with front drive B-3 and frame

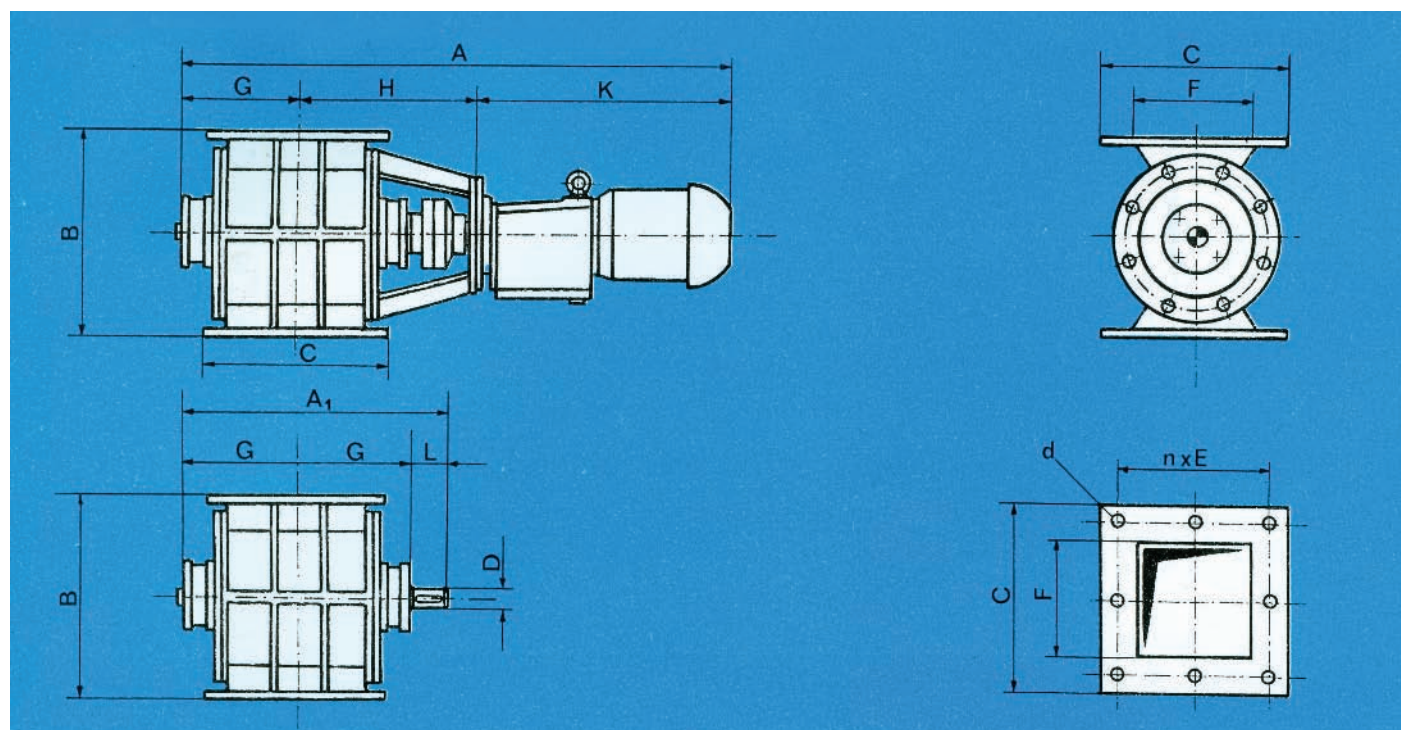
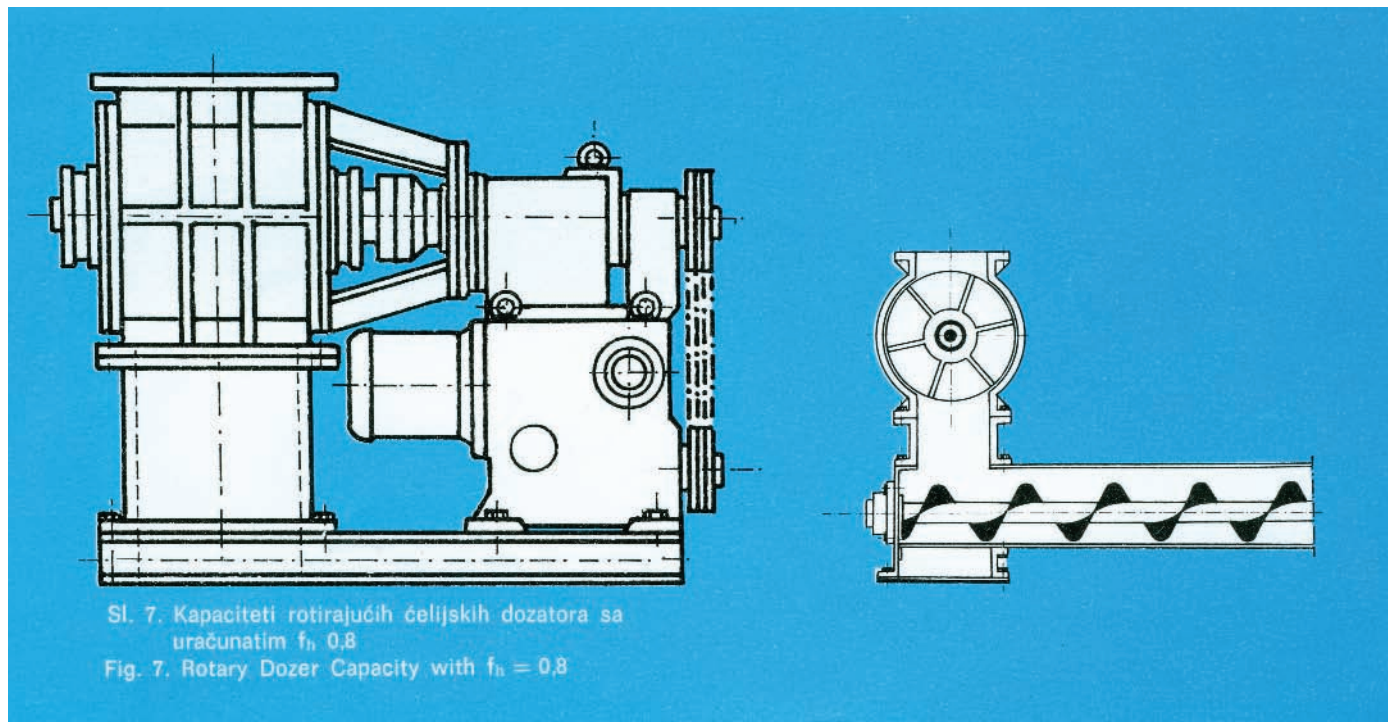

Tip Type	M J E R E D I M E N S I O N S											
	A	A ₁	B	C*	D	n x E	F*	G	H	K*	L	d
Do-200-1	929	420	350	320	30	2x135	200	180	304	445	60	16
Do-300-1	1259	540	450	460	35	4x95	300	230	489	540	60	18
Do-400-1	1726	640	540	560	40	4x120	400	280	889	557	80	18

*ovisno o tipu reduktora

*depending on gera type

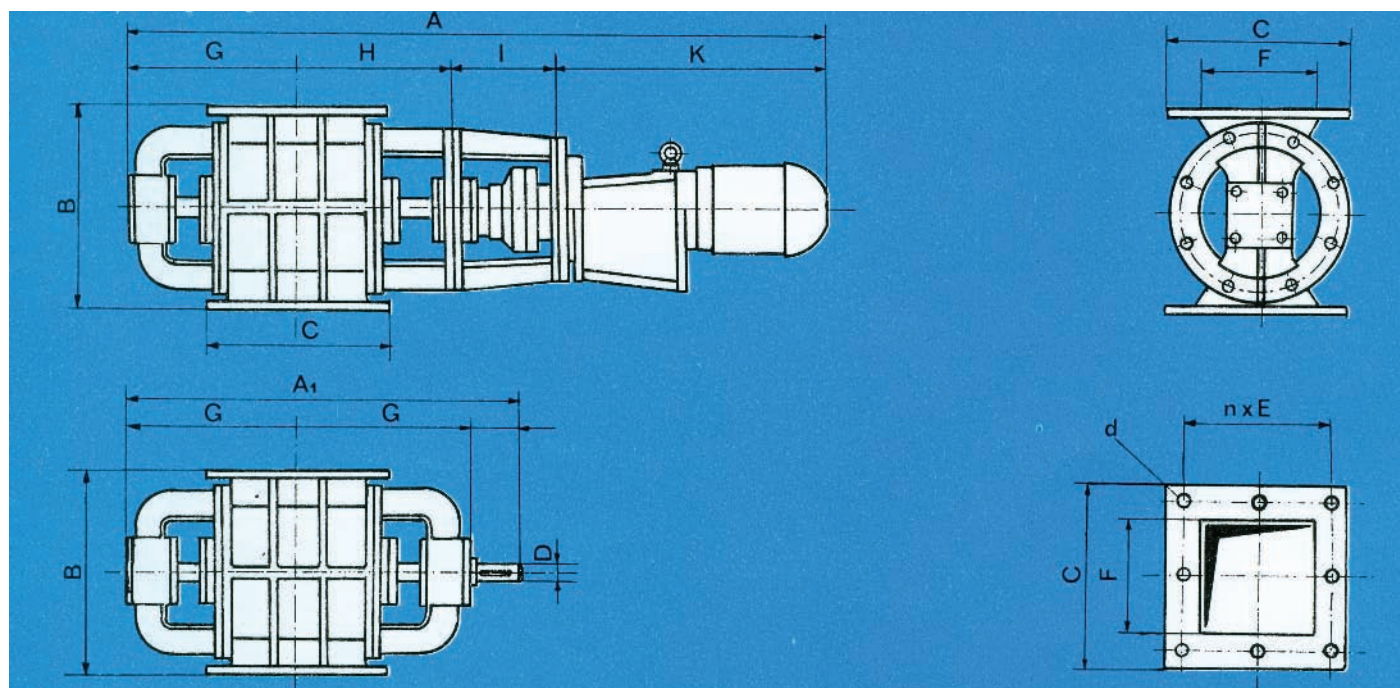

Tip Type	M J E R E D I M E N S I O N S												
	A	A ₁	B	C*	D [∅]	n x E	F*	G	H	I	K*	L	d
Do-200	1223	690	350	320	35	2x135	200	300	272	184	467	90	16
Do-300	1554	860	450	460	40	4x95	300	350	335	314	525	100	18
Do-400	1790	900	540	560	44	4x120	400	400	400	264	762	100	18

*ovisno o tipu reduktora
*depending on gera type



Sjedište / Head Office

Vlaška 78/II
10000 Zagreb, Hrvatska-Croatia

Tel.:

+385 1 6524 616
+385 1 6531 291
+385 1 6530 891

Fax.:

+385 1 6531 289
+385 1 6530 861

**Proizvodni pogon /
Production Plant**

49246 Marija Bistrica
Stubička 3, Hrvatska-Croatia

Tel.:

+385 49 382 999

Fax.:

+385 49 382 990

Email:

info@ventilator.hr
uprava@ventilator.hr
www.ventilator.hr

**Predstavništvo Srbija /
Branch office in Serbia**

Ventilator-TVUS d.o.o.
Bulevar oslobođenja 197
11000 Beograd
Tel./Fax: +381 11 3976 997

**Predstavništvo Makedonija /
Branch office in Macedonia**

Ventilator TVUS DOOEL
Georgi Sugare 2/II-24
1000 Skopje
Tel./Fax.: +389 2 2700 260
+389 2 2700 119
+389 2 2780 210

**Korporativni partneri /
Cooperative partners**

ELEX AG, Switzerland
TROGES AG, Austria